

Conductive Plastic Angle Sensor

CPP-45Bx2



- Conductive Plastic Angle Sensor (Dual Output)
- Effective Electrical Travel : 350°
- Independent Linearity : ±0.3% (Special Linearity : ±0.1%)
- Servo Mount and Screw Mount

【Material】

- Housing : Aluminum
- Shaft : Stainless Steel
- Ball Bearing : Stainless Steel

Dimension [mm]

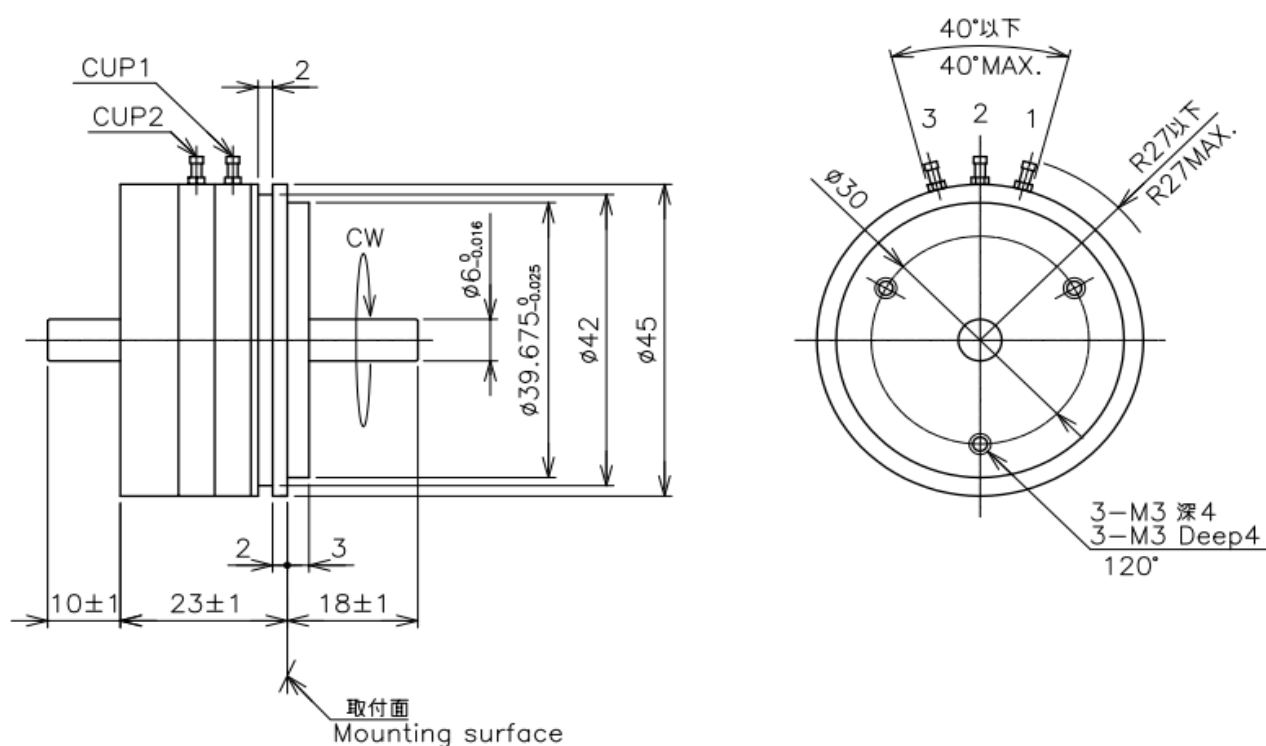

Output Characteristics

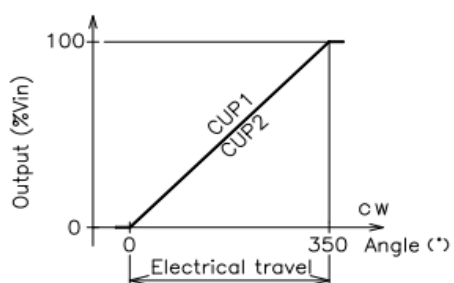

Schematic

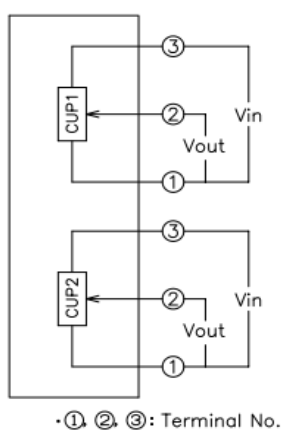

Mounting

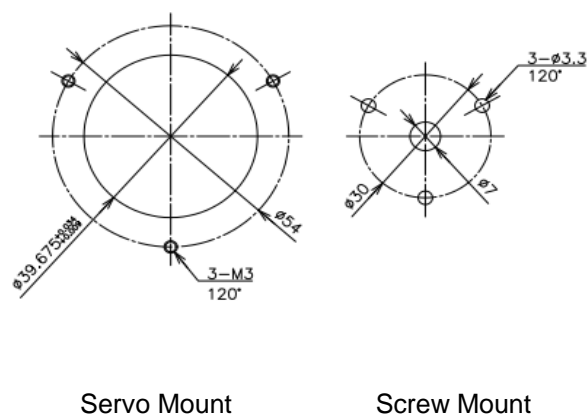

【Model No.】	CPP-45Bx2
--------------------	------------------

【Electrical Specifications】

Effective Electrical Travel	350 +2, -3 (CUP1·2)	°
Total Resistance	0.5, 1, 2, 5, 10, 20 (CUP1·2)	kΩ
Total Resistance Tolerance	±15 (CUP1·2)	%
Independent Linearity	±0.3 (CUP1·2) , Special Linearity ±0.1% (CUP1·2)	%
Rated Dissipation	1.8/70°C	W
Output Smoothness	MAX. 0.1 (CUP1·2)	%
Insulation Resistance	MIN. 100/DC1000V	MΩ
Dielectric Strength	AC1000/1 Minute	V
Temperature Coefficient of Resistance	±400	ppm/K

【Mechanical Specifications】

Total Mechanical Travel	360 Endless	°
Torque	MAX. 3.3	mN·m
Thrust Load Tolerance	2	N
Radial Load Tolerance	6	N
Mass	Approx. 70	g

【Environmental Specifications】

Life Cycles	10 Million	Cycle
Category Temperature Range	-40 ~ +120	°C
Storage Temperature Range	-40 ~ +120	°C
Vibration	150m/s ² 2000Hz 3 axis 2 hours each	
Shock	500m/s ² 11ms 6 directions 3 times	

■Accessories

Mounting Cleats : 3 pieces

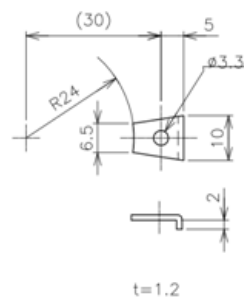
**■Handling Instruction**

- To avoid burnout of resistive element, do not supply more than 1mA current to terminal 2.
- Miswiring might cause burnout of resistive element.
- To reduce sliding noise, add load resistance should be more than 100times and less than 1000times of total resistance.
- Slight continuous vibration such as dither might cause short lifetime of the sensor.