

Contact (Wire Wound) Angle Sensor

HP-16 Series



- Contact Wire Wound Angle Sensor (Multi-turns Sensor)
- Effective Electrical Angle : 3600° (10-turn)
- Independent Linearity : ±0.25%
- Bushing Mount
- This unit is used with counting dial D-12, D-14, and DM-15

【Material】

- Housing : Nylon, Copper Alloy
- Shaft : Stainless Steel

Dimension [mm]

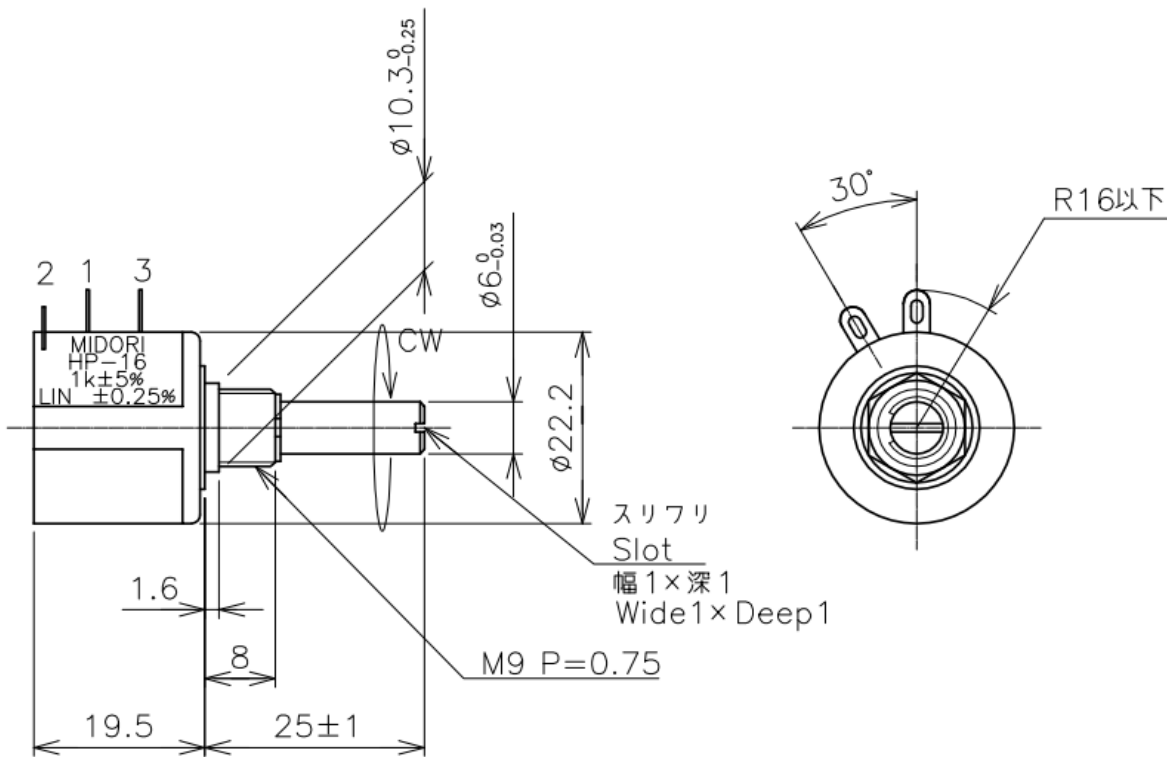

Output Characteristics

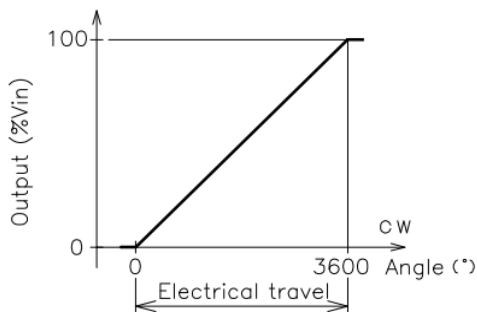

Schematic

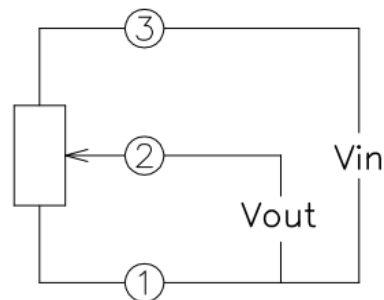

• ①, ②, ③: Terminal No.

【Model No.】	HP-16
--------------------	--------------

【Total Resistance】

Total Resistance	Resolution	Input Voltage
0.1kΩ	0.060%	12V(40°C)
0.2kΩ	0.037%	20V(40°C)
0.5kΩ	0.031%	30V(40°C)
1kΩ	0.025%	40V(40°C)
2kΩ	0.021%	60V(40°C)
5kΩ	0.016%	80V(40°C)
10kΩ	0.017%	100V(40°C)
20kΩ	0.015%	150V(40°C)
50kΩ	0.009%	200V(40°C)
100kΩ	0.007%	200V(40°C)

【Electrical Specifications】

Effective Electrical Travel	3600	°
Total Resistance Tolerance	±5	%
Independent Linearity	±0.25	%
Rated Dissipation	2(40°C)	W
Insulation Resistance	MIN. 100/DC1000V	MΩ
Dielectric Strength	AC1000/1 Minute	V
Temperature Coefficient of Resistance	MAX. 20	ppm/K
End Output Voltage	MAX. 0.25	%
Equivalent Noise Resistance	MAX. 100	Ω

【Mechanical Specifications】

Total Mechanical Travel	3600 +10, 0	°
Torque	(Starting Torque) MAX. 3.4 (Running Torque) MAX. 2.5	mN·m
Mass	Approx. 22	g
Stopper Strength	MIN. 540	mN·m

■Accessories

M9 Nut
Internal toothed lock washer 1 piece each

■Handling Instruction

- Winding resistance may oxidizes and causes sliding noise even this sensor is unused for a long time.
- Miswiring might cause burnout of resistive element.
- To reduce sliding noise, add load resistance should be more than 100times and less than 1000times of total resistance.
- Slight continuous vibration such as dither might cause lifetime of the sensor.
- To avoid damage of stopper, do not rotate the shaft at the end with excessive force.