



**TOMY INDUSTRIAL CO., LIMITED**

**东 镁 电 子 工 业 有 限 公 司**

Unit 1,6/F, Heng Ngai Jewelry Centre, No.4 Hok Yuen Street East, HUNG HOM

Kowloon Hong Kong

TEL: (852) 2765 6486

FAX: (852) 2764 8168

# SPECIFICATIONS

## 规 格 书

# POTENTIOMETER

## 电 位 器

**MODEL NO. 产品型号:** RV1030N-V1-B10K-JS-65°

**ISSUE DATE 发出日期:** 2006 年 05 月 30 日

## CUSTOMER APPROVAL

## 客 户 核 准

**NAME OF CUSTOMER 客户名称:**

**CUSTOMER P/N. 客户编号:**

**Please sign this sheet after your approval & kindly return us a Reference Copy!**  
**贵客核准后,请提供参考副本!**

**APPROVAL SIGNATURE & DATE 核准签署及日期**



**TOMY INDUSTRIAL CO., LIMITED**

**东 镁 电 子 工 业 有 限 公 司**

Unit 1,6/F, Heng Ngai Jewelry Centre, No.4 Hok Yuen Street East, HUNG HOM  
Kowloon Hong Kong TEL: (852) 2765 6486 FAX: (852) 2764 8168

**>>> GENERAL SPECIFICATIONS <<<**

MODEL NO.	RV1030N-V1-B10K-JS-65°-500KL-3.8F ±20%
-----------	--

**ELECTRICAL CHARACTERISTICS**

- |                               |                                   |
|-------------------------------|-----------------------------------|
| 1. Total resistance           | :B10K Ω                           |
| 2. Total resistance tolerance | :B10K±20%                         |
| 3. Resistance taper           | :B Curve                          |
| 4. Power rating               | :0.0125w                          |
| 5. Maximum operating voltage  | :50V AC/5V DC                     |
| 6. Residual resistance        | :(Between terminal 1&2)Max. 300 Ω |
| 7. Residual resistance        | :(Between terminal 2&3)Max. 300 Ω |
| 8. Rotational noise           | :Less than 300 MV                 |
| 9. Insulation resistance      | :More than 50 MΩ at 500v DC       |
| 10. Voltage proof             | :1 minute at 500v AC              |



**MECHANICAL CHARACTERISTICS**

- |                                    |                       |
|------------------------------------|-----------------------|
| 1. Dimensions                      | :See attached drawing |
| 2. Total mechanical rotation angle | :300° ±5°             |
| 3. Effective working angle         | :65° ±5°              |
| 4. Stopper strength                | :3kgf. cm             |
| 5. Push-pull strength              | :2kgf                 |
| 6. Rotational torque               | :10~100gf gf. cm      |
| 7. shaft wobble                    | :0.8xL/20mm p-p max   |
| 8. shaft bending                   | :0.35mm               |
| 9. rotational cycles               | :Min 500,000 cycles   |

**OTHER CHARACTERISTICS**

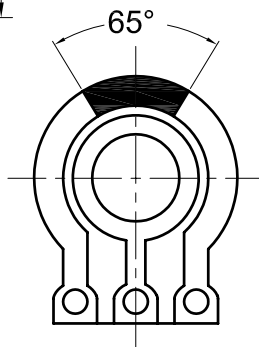
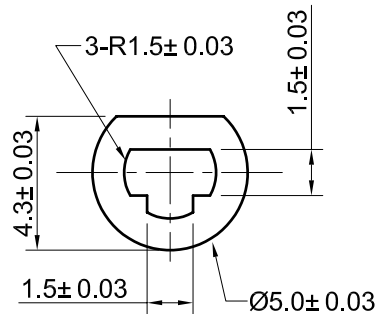
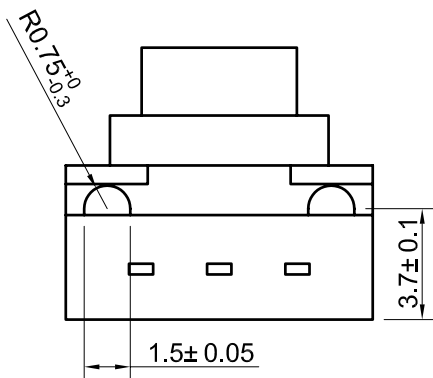
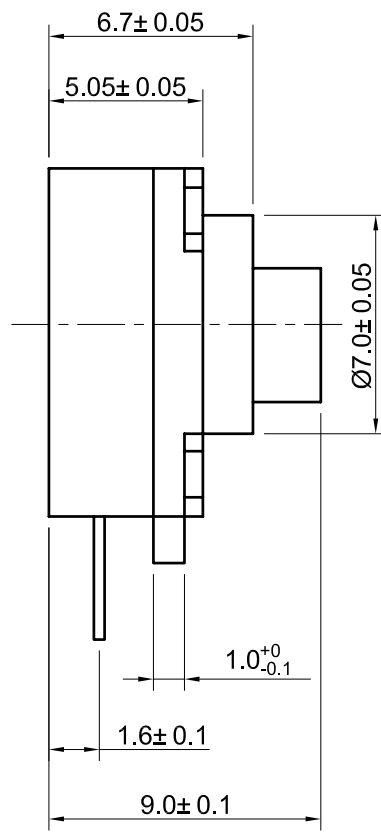
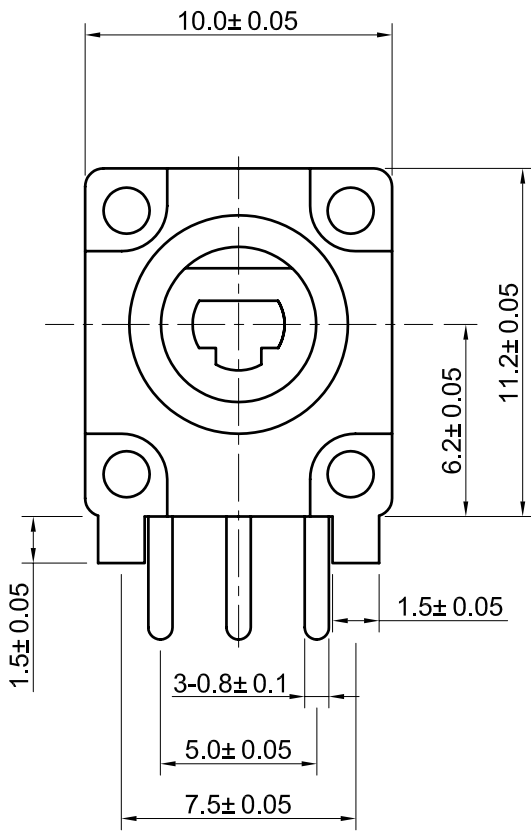
- |                          |  |
|--------------------------|--|
| 1. Terminal strength     | :No poor contact after soldering         |
| 2. Soldering conditions  | :Max 300 °C within 3 seconds             |
| 3. Other characteristics | :Comply with or exceed jis6443 standards |



 		Tolerances Unless Otherwise Specified				TOMY INDUSTRIAL CO., LIMITED	
SCALE	UNIT	L<10	±0.3		DRAWING TITLE		
	mm	10<L<100	±0.5				RV1030N SERIES
Revision Notes		100<L	±0.8		DRAWING NAME		
		Angular Dimension	±5°				RV1030N-V1-65
		DESIGNED	DRAWN	CHECKED	APPROVED	DRAWING NO.	
			EDDIE WONG	Alan Lan	Anson Yu		